

Neb - Instruments

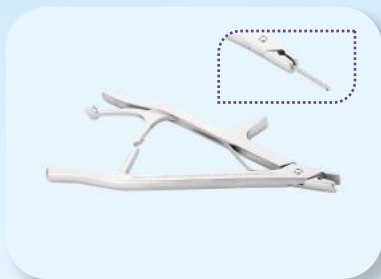
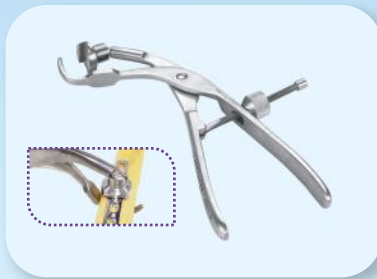

Index

300 BASIC INSTRUMENTS.	03
400 OTHER INSTRUMENTS	17
500 PLASTER INSTRUMENTS	22
600 WIRE INSTRUMENTS	24
700 SPINE INSTRUMENTS	30
800 BONE HOLDING FORCEPS / CLAMPS	34
S800 BONE HOLDING FORCEPS / CLAMPS (S.Q)	39
900 BONE LEVERS / RETRACTORS / ELEVATORS	41
1000 OSTEOTOMES / GAUGE / CHISEL	52
1200 A. M. PROSTHESIS INSTRUMENTS	54
1300 4.0 MM C.C. SCREW INSTRUMENTS	56
1400 6.5 MM C.C. SCREW INSTRUMENTS	57
1500 D.H.S. / D.C.S. SCREW INSTRUMENTS	59

Index

1600 D.H.S. / D.C.S. SCREW (Q.C.) INSTRUMENTS	60
- PEDIATRIC INSTRUMENT FOR D.H.S	63
1700 HARBERT SCREW INSTRUMENTS	64
1800 STAPLE INSTRUMENTS	65
1900 NAILING (RADIUS / ULNA) INSTRUMENTS	66
2000 INTRAMEDULLAR INSTRUMENTS	68
2200 ENDER'S NAIL INSTRUMENTS	70
3000 FOR MINI PLATES INSTRUMENT SET	71
3100 ELASTIC NAIL INSTRUMENT SET	74
3200 BIPOLAR INSTRUMENT SET	76
G.100 GENERAL INSTRUMENT	78



**Cat. No. :301
Drill Sleeve With Trocar**

Product No. For Order

- 301.41 = 4 in 1
(6.0, 4.5, 3.2 mm)
- 301.31TH = 3 in 1
(5.0, 3.5 mm)
- 301.31RU = 3 in 1
(4.0, 2.7 mm)
- 301.31F = 3 in 1 (Long)
(5.0, 3.5 mm)



**Cat. No. :303
Drill Bits Long S.S.**

Product No. For Order

- 303.04 = 4" (All Size)
- 303.05 = 5" (All Size)
- 303.06 = 6" (All Size)
- 303.08 = 8" (All Size)
- 303.10 = 10" (All Size)
- 303.12 = 12" (All Size)



**Cat. No. :303
Flexible Drill Bits**

Product No. For Order

- 303.F = (All Size)



**Cat. No. :304
Quick Coupling Drill Bits**

Product No. For Order

- 304.06 = 6" (All Size)
- 304.08 = 8" (All Size)
- 304.10 = 10" (All Size)



**Cat. No. :303.S
Drill Bits S.S. (S.Q.Tit. Coated)**

Product No. For Order

- 303.S.06 = 6" (All Size)
- 303.S.08 = 8" (All Size)
- 303.S.10 = 10" (All Size)

300 • BASIC INSTRUMENT

Cat. No. :304.S Quick Coupling Drill Bits (S.Q. Tit. Coated)

Product No. For Order

304.S.06 = 6" (All Size)
304.S.08 = 8" (All Size)
304.S.10 = 10" (All Size)



Cat. No. :305 Drill Sleeve With Handle

Product No. For Order

305.25 = 2.5 mm
305.27 = 2.7 mm
305.32 = 3.2 mm



Cat. No. :305 Drill Sleeve

Product No. For Order

305.L = For LCP Screw (S.S.)
(2.7, 3.5, 4.9, 6.5 mm)
For C.C. Screw
(4.9, 7.3 mm)
305.V = For Variable Angle
305.TL = For LCP Screw (TIT)
(2.7, 3.5, 4.9, 6.5 mm)



Cat. No. :306 Tap Sleeve With Handle

Product No. For Order

306.27-65 = 2.7, 3.5 mm
4.5, 6.5 mm



Cat. No. :307 Drill & Tap Sleeve Combine A.O. Type

Product No. For Order

307.A.2535 = 2.5 X 3.5 mm
307.A.2735 = 2.7 X 3.5 mm
304.A.3245 = 3.2 X 4.5 mm
304.A.3265 = 3.2 X 6.5 mm





Cat. No. :307.I
Insert Drill Sleeve

Product No. For Order

307.I.3525 = 3.5 X 2.5 mm

307.I.4532 = 4.5 X 3.2 mm



Cat. No. :308
Triple Drill Guide 2.0 MM



Cat. No. :309
D.C.P. Drill Guide Netural & Load

Product No. For Order

309.35 = 2.5 X 3.5 mm

309.45 = 3.2 X 4.5 mm



Cat. No. :309.U
Universal Drill Sleeve

Product No. For Order

309.2027 = 2.0 X 2.7 mm

309.2735 = 2.7 X 3.5 mm

309.3245 = 3.2 X 4.5 mm



Cat. No. :310
Depth Gauge With Laser Marking

310.27-35-45 = For 2.7, 3.5, 4.5 mm

310.L = For Tibia & Femur,
Humerus, IMSC, Cyrus Tibia

310.EL = For PFN, Recon, Cyrus Femur

300 • BASIC INSTRUMENT

**Cat. No. :311
Drill & Screw Gauge**



**Cat. No. :314
Bone Tap**

Product No. For Order

314.27-65 = 2.7, 3.5 mm
4.5, 6.5 mm

314.L = For LCP Screw
3.5, 4.9 mm

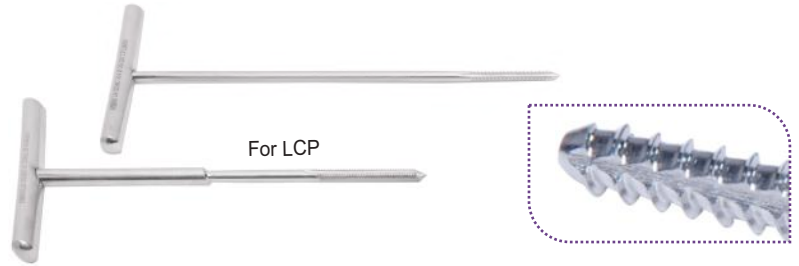

**Cat. No. :315
T Handle With Q.C.**

USE :-For Bone Tap & Drill Bit



**Cat. No. :316
Bone Tap Q.C.**

Product No. For Order

316.27 = 2.7 mm
316.35 = 3.5 mm
316.45 = 4.5 mm



**Cat. No. :317
Countersink With T-Handle**

Product No. For Order

317.60 = 6.0 mm Head

317.80 = 8.0 mm Head

317.Q.60 = 6.0 mm Head
For Q.C.

316.Q.80 = 8.0 mm Head
For Q.C.

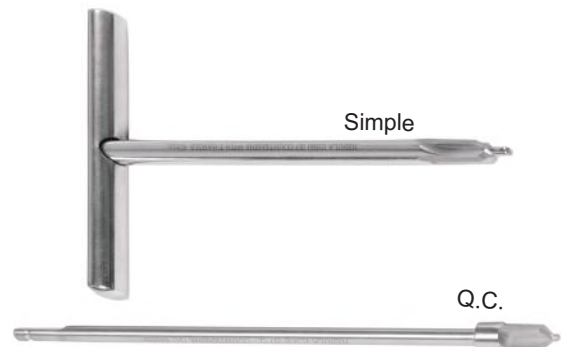



Cat. No. :318
Screw Holding Forcep

Product No. For Order

318.35 = 3.5 mm

318.45 = 4.5 mm



Cat. No. :319
Cannulated Cutter With Protection Sleeve

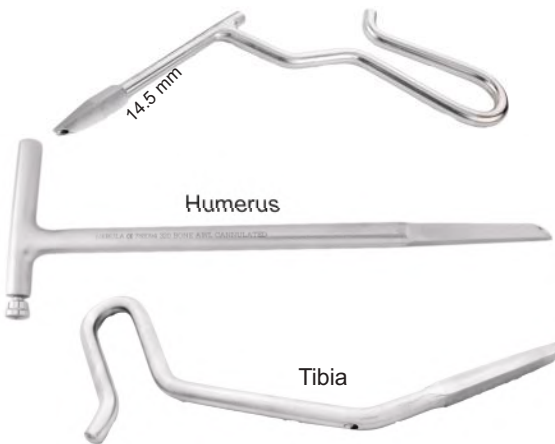

Cat. No. :320
Bone Awl Cannulated

Product No. For Order

320.H = For Humerus

320.LF = For Femur

320.T = For Tibia

320.14 = 14.5 mm
For Only Femur

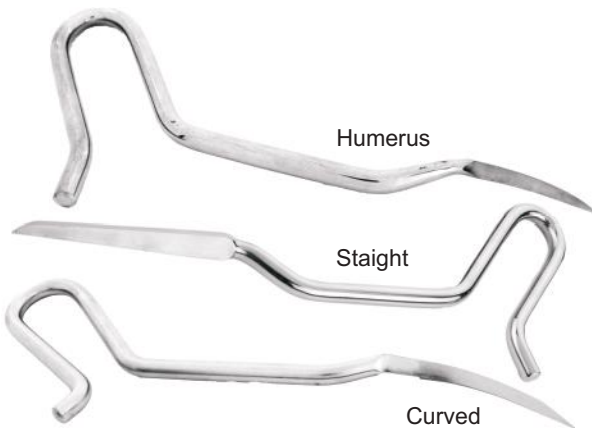

Cat. No. :321
Bone Awl Diamond Pointed

Product No. For Order

321.H = Humerus

321.S = Staight

321.C = Curved

300 • BASIC INSTRUMENT

Cat. No. :322 Screw Driver

Product No. For Order

- 322.O = Ordinary Screw Driver
(322.O.S-L = Small , Large)
- 322.61 = 6 in 1
- 322.QC = Screw Driver Q.C.
(322.QC.27-45 = 2.7, 3.5, 4.5 mm)
- 322.T = Torque Limited Screw Driver
(322.T.27-45 = 2.7, 3.5, 4.5 mm)
- 322.S = Self Holding Screw Driver
(322.S.35-45 = 3.5, 4.5 mm)
- 322.H = Screw Driver With Holding Sleeve
(322.H.27-35 = 2.7, 3.5 mm)

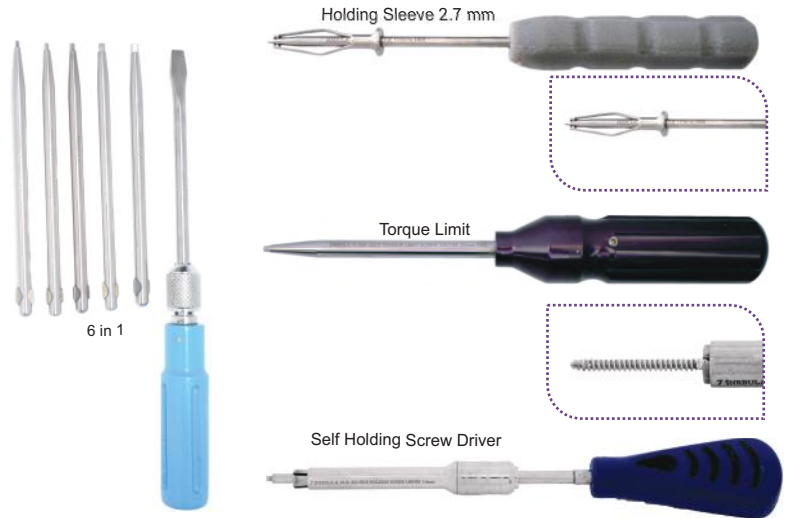

Cat. No. :323 Screw Driver

Product No. For Order

- 323.S.27 = 2.7 mm X 150 mm
- 323.S.35 = 3.5 mm X 150 mm
3.5 mm X 200 mm
- 323.S.45 = 4.5 mm X 150 mm
4.5 mm X 200 mm
4.5 mm X 250 mm

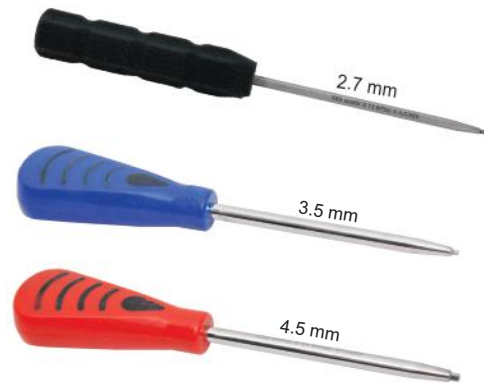

Cat. No. :323.F Flexible Screw Driver

Product No. For Order

- 323.F.35 = 3.5 mm
- 323.F.45 = 4.5 mm



Cat. No. :323.C C.C. Screw Driver 5.0 mm Hex

Product No. For Order

- 323.C20 = 200 mm
(PF / LCP)
- 323.C25 = 250 mm
(PF Nail)

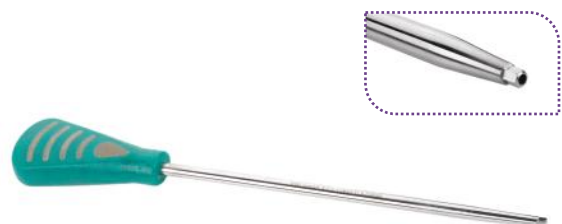



**Cat. No. :324
Spanner Ordinary**

Product No. For Order

324.001 = 8 X 9, 10 X 11

324.002 = 18 X 19
For (T/F, Recon, I.M.S.C., P.F.N.)

324.003 = 16 X 17
For (P.F.N.)

324.004 = 14 X 15
For (Humerus)

324.005 = 12 X 13
For (Humerus)



**Cat. No. :325
Plate Bending Pair**

Product No. For Order

=> SMALL

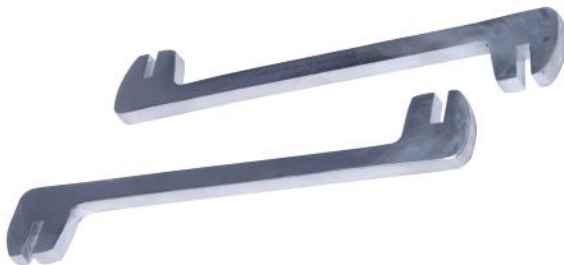

**Cat. No. :326
Plate Bending Pair**

Product No. For Order

=> BIG



**Cat. No. :327
Roller Type Plate & Rod Bender**



**Cat. No. :328
Plate Bending Press**

300 • BASIC INSTRUMENT

Cat. No. :329
Bone Awl With Fiber Handle



Cat. No. :330
Rod Pin Cutter Silver

Product No. For Order

330.O = Ordinary Handle

330.A = Alluminium Handle



Cat. No. : S330
Rod Pin Cutter S.S.

Product No. For Order

S330.20 = 20"



Cat. No. :332
Hollow Mill Set Of 3

Product No. For Order

332.S = Simple

332.D = Detchable

332.Q = Q.C.

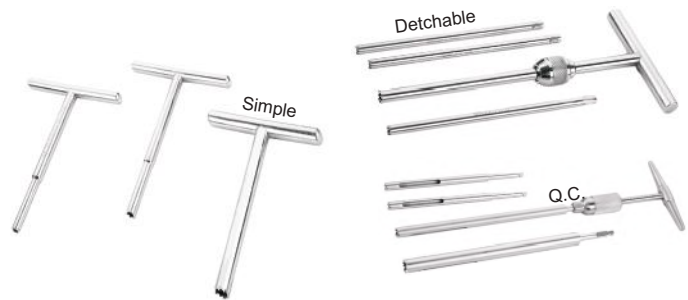

Cat. No. :332
Hollow Mill Set Of 3

Product No. For Order

332.10L = 10 mm Long

332.11L = 11 mm Long

332.12L = 12 mm Long

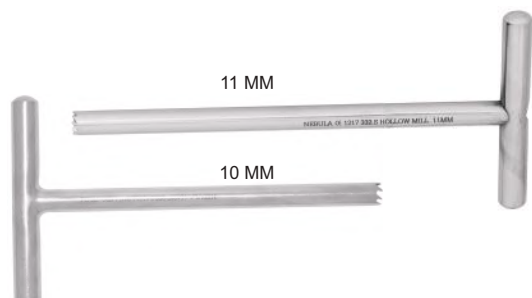



Cat. No. :333
Sharp Hook



Cat. No. :334
Universal Bone Drill With Chuck



Cat. No. :335
Open Gear Bone Drill With Chuck



Cat. No. :336
Micro Bone Drill With Chuck



Cat. No. :337
Reconstruction Plate Bender



Cat. No. :338
LCP RCP Plate Bender Pair (A.O. Type)

300 • BASIC INSTRUMENT

Cat. No. :339
Extra Chuck & Key S.S.

Product No. For Order

339.01 = Extra Chuck

339.02 = Extra Key



Cat. No. :340
F Tool

Product No. For Order

=> Regular(17.5" Length)

=> Long(20.5" Length)



Cat. No. :341
Proximal Reamer (With Silicon Handle)

Product No. For Order

341.11 = 11 mm

341.13 = 13 mm

341.15 = 15 mm

341.H = Humerus

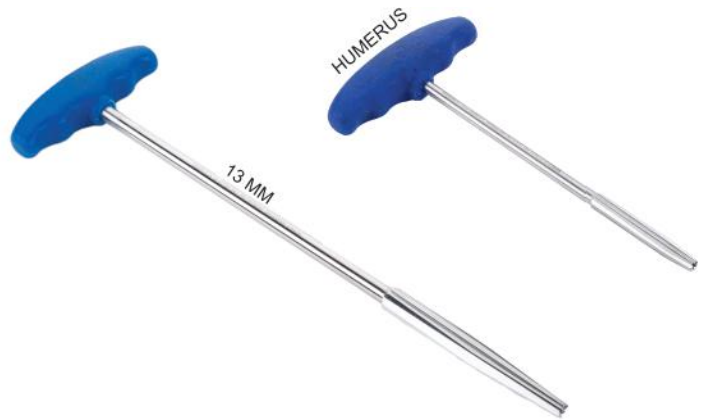

Cat. No. :342
Fosa Finder



Cat. No. : 343
Tissue Protector

Product No. For Order

343.S = Simple

343.13-15 = Solapur Sleeve
(13 mm & 15 mm)

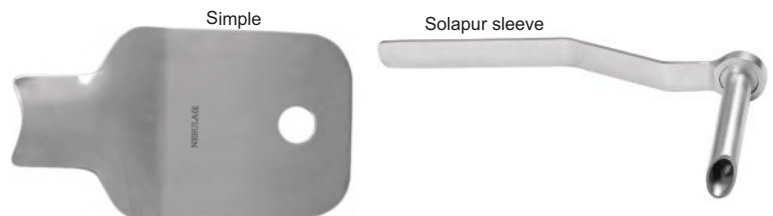



Cat. No. :344
Fiber Handle Distal Device With Pin



Cat. No. :344.P
Plier With Fiber Jaw For Distal Device

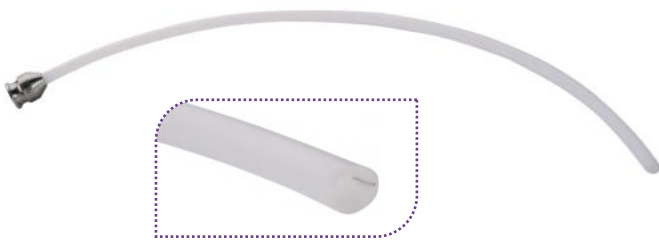

Cat. No. :345
Teflon Tube

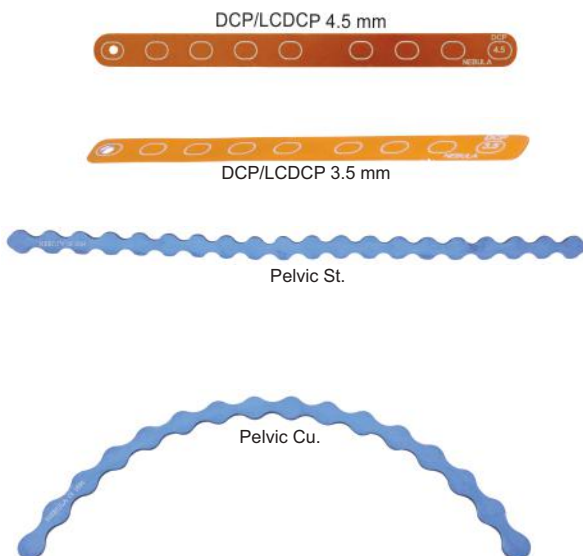

Cat. No. :347
Template

Product No. For Order

- 347.35 = Template For 3.5 mm DCP / LCDCP
(347.35.07-12 = 07, 09, 12 HOLE)
- 347.45 = Template For 4.5 mm DCP / LCDCP
(347.45.07-12 = 07, 09, 12 HOLE)
- 347.PS = Template For 3.5 mm Pelvic ST. Plate
(347.PS.08-20 = 08, 14, 20)
- 347.PC = Template For 3.5 mm Pelvic CU. Plate
(347.PC.06-16 = 06, 12, 16)

300 • BASIC INSTRUMENT

**Cat. No. :S348
Anti-Skidding Extractor**

Product No. For Order

S348.25 = 2.5 mm

S348.35 = 3.5 mm

S348.45 = 4.0 mm

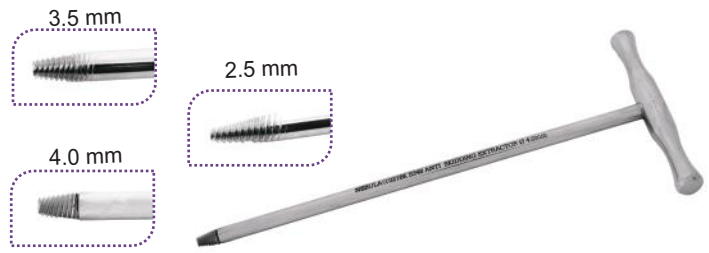

**Cat. No. :349
Broken Nail Removal**

Product No. For Order

349.S = Simple

349.H = Hook Type

349.T = Trocar

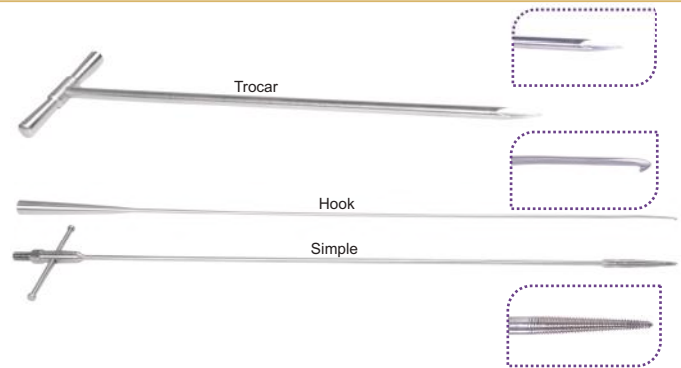

**Cat. No. :350
Nail Removal Set**

Product No. For Order

For Any Type Of Nail

350.C = Conical Bolt
(16, 18, 20, 22, 24 T.P.I.)



**Cat. No. :351
Screw Removal Forceps Plier Type**



**Cat. No. :352
Nail Removal Plier With Extraction**



**Cat. No. :353
Screw Removal Forceps With Ratchet**

Product No. For Order

353.35 = 3.5 mm

353.45 = 4.5 mm



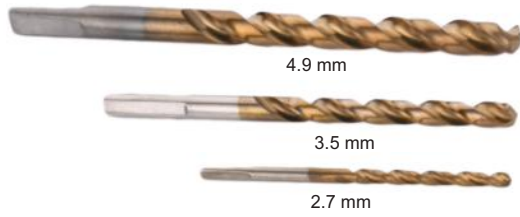

Cat. No. : 354
Drill Bits For Screw Head Break

Product No. For Order

354.27 = 2.7 mm
354.35 = 3.5 mm
354.49 = 4.9 mm



Cat. No. :355
Graft Awl



Cat. No. :356
Transportation Tube With Pusher

Product No. For Order

156.8 = 8.0 mm
156.9 = 9.0 mm
156.10 = 10 mm



Cat. No. :357
Staple Pin Removal



Cat. No. :S357
Bone Graft Funnel



Cat. No. :358.001
Broken Screw Extractor T-Handle

300 • BASIC INSTRUMENT

Cat. No. :358.002
Broken Screw Extractor Plier With Ratchet



Cat. No. :358.003
Broken Screw Conical Extraction

Product No. For Order

358.003.2514 = 2.5 mm (14 TPI)
358.003.2520 = 2.5 mm (20 TPI)
358.003.35 = 3.5 mm
358.003.40 = 4.0 mm

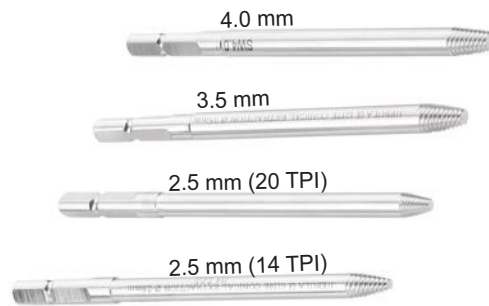

Cat. No. :358.004
Broken Screw Hollow Mill Set

Product No. For Order

358.004.65 = 6.5 mm
358.004.08 = 8.0 mm

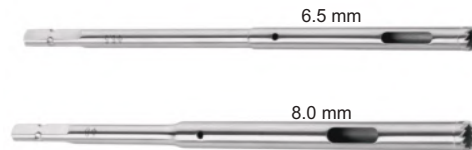

Cat. No. :358.005
Broken Screw Drill Bit H.S.S.

Product No. For Order

358.005.04 = 4.0 mm
358.005.06 = 6.0 mm
358.005.08 = 8.0 mm

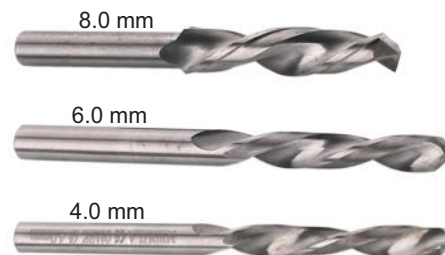



**Cat. No. : 401
Hammer S.S. Handle**

Product No. For Order

- 401.S = (250gm) Small
- 401.M = (350 gm) medium
- 401.L = (500 gm) Large
- 401.EX = (750 gm) Ex. Large



**Cat. No. :401.F
Hammer Fiber Handle**

Product No. For Order

- 401.F.S = Small
- 401.F.M = Medium
- 401.F.L = Large



**Cat. No. :402.O
Hammer Nylon Face (One Sided)**

Product No. For Order

- 402.O.S = Small
- 402.O.M = Medium
- 402.O.L = Large



**Cat. No. :402.D
Hammer Nylon Face (Double Sided)**

Product No. For Order

- 402.D.S = Small
- 402.D.M = Medium
- 402.D.L = Large

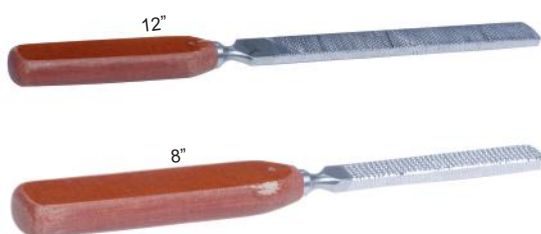

**Cat. No. :403.F
Bone File With Fiber Handle**

Product No. For Order

- 403.F.08 = 8"
- 403.F.12 = 12"

400 • OTHER INSTRUMENT

**Cat. No. :403.Q
Bone File S.S. Handle(Two Sided)**

Product No. For Order

403.Q = Bone File S.S. Handle
(Two Sided)

403.QP = Putti Bone Rasp
(Double Ended)

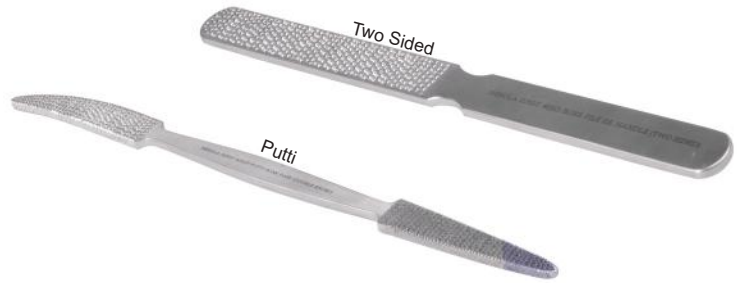

**Cat. No. :404
Bohler Stirrup**

Product No. For Order

404.10 = Ex.Small 10 "

404.12 = Small 12 "

404.15 = Medium 15 "

404.18 = Large 18 "

404.21 = Ex.Large 21 "

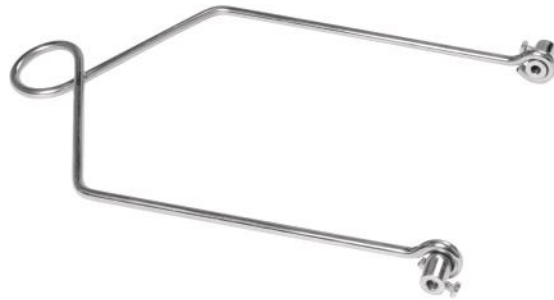

**Cat. No. :405
Crutchfield Tong**

Product No. For Order

405.S = Small

405.M = Medium

405.L = Large



**Cat. No. :406
Gardener-Wells Traction Tong**

Product No. For Order

406.S = Small

406.B = Big



**Cat. No. :407
Charnelys Clamp Pair**



**Cat. No. :408
T Handle With Chuck (With Silicon Handle)**





Cat. No. :S408
T Handle With Chuck (S.S.)



Cat. No. :408.K
T Handle With Chuck - Key Less

Product No. For Order

408.K.S = Small
408.K.B = Big



Cat. No. :409
Cannulated Reamer

Product No. For Order

409.006-014 = 6 mm To 14 mm



Cat. No. :410
Femoral Distractor A.O. Type New 2 in 1



Cat. No. :411
Esmarch Rubber Bandage

Product No. For Order

411.04 = 04"
411.06 = 06"

400 • OTHER INSTRUMENT

Cat. No. :412
Radiography Scale

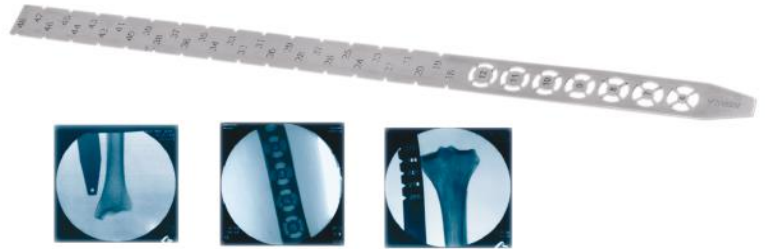

Cat. No. :413
Flexible Reamer Fix Tip

Product No. For Order

413.08 -13 = 08 mm To 13 mm
(0.5 variation)

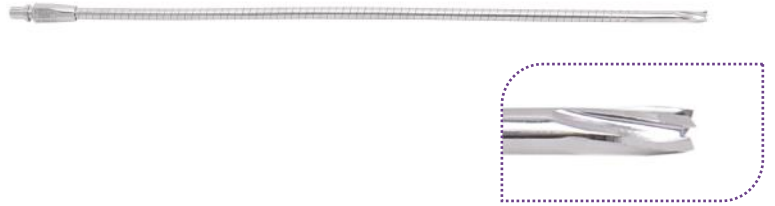

Cat. No. :413.S
Hadson Type Flexible Ramer

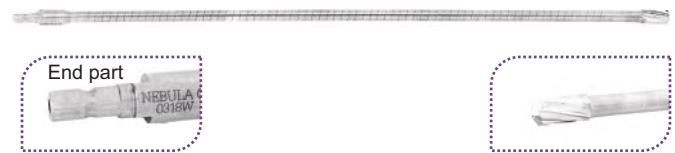

Cat. No. :414
Flexible Reamer Shaft (For Detchable)

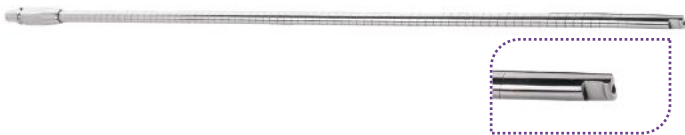

Cat. No. :415
Reamining Bits

Product No. For Order

415.08-13 = 8.5mm To 13 mm
(0.5 mm variation)



Cat. No. :416
Skin Grafting Handle



Cat. No. :417
Blade For Skin Grafting Handle





**Cat. No. :418
Syringe Kit For Cement Gun**



**Cat. No. :419
T - Handle For Cement Retractor**



**Cat. No. :420
C Chain Retractor with 2 Blade**



**Cat. No. :421
Cement Gun(S.S.)**



**Cat. No. :422
Ankle Compressor**



**Cat. No. :423
Ankle Spreader**



**Cat. No. :423.W
Ankle Spreader With Wide Arms**

500 • INSTRUMENT FOR PLASTER

Cat. No. :501
Plaster Saw ordinary Heavy



Cat. No. :502
Plaster Saw Angle



Cat. No. :503
Finger Saw



Cat. No. :504
Electric Plaster Cutter With 2 Blade



Cat. No. :505
Extra Blade For E.P.Saw

Product No. For Order

505 = Small
505.F = Big (For Fiber Cast)

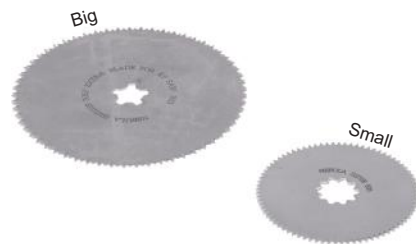

Cat. No. :506
Plaster Spreader





Cat. No. :507
Plaster Cutting Scissor Finger Type



Cat. No. :508
Plaster Cutting Scissor With Spring



Cat. No. :509
Plaster Bender



Cat. No. :509.S
Plaster Bender (Super Quality)



Cat. No. :510
Plaster Opener Daw's

600 • INSTRUMENT FOR WIRE

Cat. No. :601
Wire Twister (Graduated)



Cat. No. :602
Nose Plier



Cat. No. :602.M
Nose Plier (Maun Type)



Cat. No. :603
Wire Cutter / plier (maun)

Product No. For Order

603.65 = 6.5 "
603.80 = 8.0 "



Cat. No. :604
K Wire Bender / Plier / Cutter S.S.

Product No. For Order

604.65 = 6.5 "
604.90 = 9.0 "



Cat. No. :605.K
K Wire Introducer

Product No. For Order

605.K.0815 = 0.8 mm To 1.5 mm
605.K.1525 = 1.5 mm To 2.5 mm





Cat. No. :605.G
Guide Wire Introducer

Product No. For Order

2.0 mm To 3.5 mm

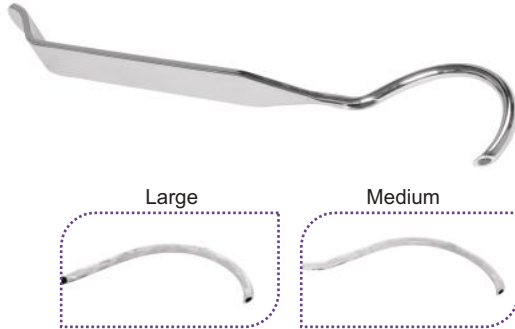

Cat. No. :606
Wire Passer S.S.

Product No. For Order

606.S = Small
606.M = Medium
606.L = Large



Cat. No. :606.P
Wire Passer For Patella

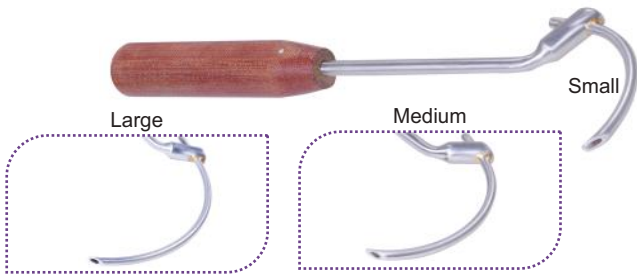

Cat. No. :606.F
Wire Passer Fiber Handle (A.O. Type)

Product No. For Order

606.F.S = Small
606.F.M = Medium
606.F.L = Large



Cat. No. :607
Guide Wire Container With Spring

Product No. For Order

40 " & 46"

600 • INSTRUMENT FOR WIRE

Cat. No. :608
Gigli Saw Introducer



Cat. No. :609
Gigli Saw Wire (Imported)



Cat. No. :610
Gigli Saw Handle (Pair)



Cat. No. :611
K Wire Bender



Cat. No. :612
K Wire Container

Product No. For Order

612.06 = 06"
612.09 = 09"
612.12 = 12"



Cat. No. 613
K Wire Cutter Circuler (Round Type)

Product No. For Order

613.09 = 09"
613.12 = 12"





Cat. No. :615
K Wire Cutter T/C (Gold)



Cat. No. :615.F
K Wire Cutter Front T/C Tip

Product No. For Order

615.F.06 = 06"

615.F.09 = 09"



Cat. No. :616
Pocket Cutter

Product No. For Order

616 = Pocket Cutter

S616 = Pocket Cutter S.S..



Cat. No. :617
Drill Bit Container

Product No. For Order

617.06 = 06"

617.09 = 09"

617.12 = 12"

617.16 = 16"



Cat. No. :618.D
K Wire Plier Double Action

Product No. For Order

618.D.08 = 08"



Cat. No. :618.S
K Wire Plier (S.S.)

600 • INSTRUMENT FOR WIRE

Cat. No. :619
Cerclage Wire Tightner



Cat. No. :620
Percutaneous Wire Passer

Product No. For Order

620.S = Small
620.L = Large



Cat. No. :621
Niddle Nose Locking Plier

Product No. For Order

621.08 = 08"
621.10 = 10"
621.12 = 12"



Cat. No. :622
Guide Wire Holding Gun



Cat. No. :S622
Sharp Crested Clipper

Product No. For Order

S622.S = Straight
S622.C = Curved



Cat. No. S623
Hercules Wire Cutter





Cat. No. :624
Dolphin cutter

Product No. For Order

624.85 = 8.5"

700 • INSTRUMENT FOR SPINE

**Cat. No. :701
Bone Nibbler (S.A.)**

Product No. For Order

701.007.S = 07"
701.009.S = 09"
701.007.C = 07"
701.009.C = 09"

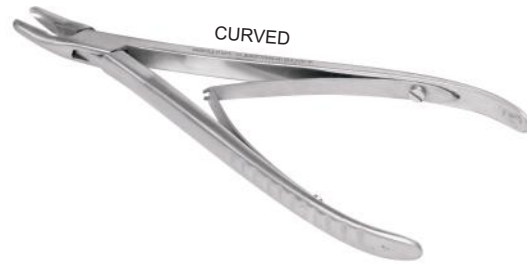

**Cat. No. :702
Bone Nibbler
(D.A.)**

Product No. For Order

702.006.S = 06"
702.007.S = 07"
702.009.S = 09"
702.006.C = 06"
702.007.C = 07"
702.009.C = 09"



**Cat. No. :702.R
Bone Nibbler (D.A.) Right Angle**

Product No. For Order

=> 06"



**Cat. No. :703
Bone Cutter (S.A.)**

Product No. For Order

703.007.S = 07"
703.009.S = 09"
703.007.C = 07"
703.009.C = 09"

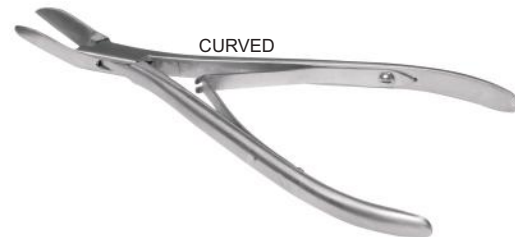

**Cat. No. :704
Bone Cutter (D.A.)**

Product No. For Order

703.007.S = 07"
703.009.S = 09"
703.007.C = 07"
703.009.C = 09"



**Cat. No. 705
Bone Nibbler (D.A.)(Big)**

Product No. For Order

705.C = Curved
705.S = Straight





Cat. No. : 706
Bone Cutter (D.A.) Big



Cat. No. : 707
Tudor Edward Bone Cutter

Product No. For Order

707.45 = 45°

707.90 = 90°



Cat. No. : 708
Lacksell Rounger

Product No. For Order

708.30 = 3.0 mm

708.40 = 4.0 mm



Cat. No. : 710
Olecrona Rounger

Product No. For Order

710.30 = 3.0 mm

710.40 = 4.0 mm



Cat. No. : 713
Disc Punch Serrated

Product No. For Order

713.20.S = 2.0 mm

713.20.U = 2.0 mm

713.20.D = 2.0 mm

713.30.S = 3.0 mm

713.30.U = 3.0 mm

713.30.D = 3.0 mm

713.40.S = 4.0 mm

713.40.U = 4.0 mm

713.40.D = 4.0 mm

700 • INSTRUMENT FOR SPINE

Cat. No. :715
Kerrison Rounger

Product No. For Order

715.45.1.D = 45° 1.0 mm DN.
715.45.1.U = 45° 1.0 mm UP.
715.45.2.D = 45° 2.0 mm DN.
715.45.2.U = 45° 2.0 mm UP.
715.45.3.D = 45° 3.0 mm DN.
715.45.3.U = 45° 3.0 mm UP.
715.45.4.D = 45° 4.0 mm DN.
715.45.4.U = 45° 4.0 mm UP.

715.90.1.D = 90° 1.0 mm DN.
715.90.1.U = 90° 1.0 mm UP.
715.90.2.D = 90° 2.0 mm DN.
715.90.2.U = 90° 2.0 mm UP.
715.90.3.D = 90° 3.0 mm DN.
715.90.3.U = 90° 3.0 mm UP.
715.90.4.D = 90° 4.0 mm DN.
715.90.4.U = 90° 4.0 mm UP.

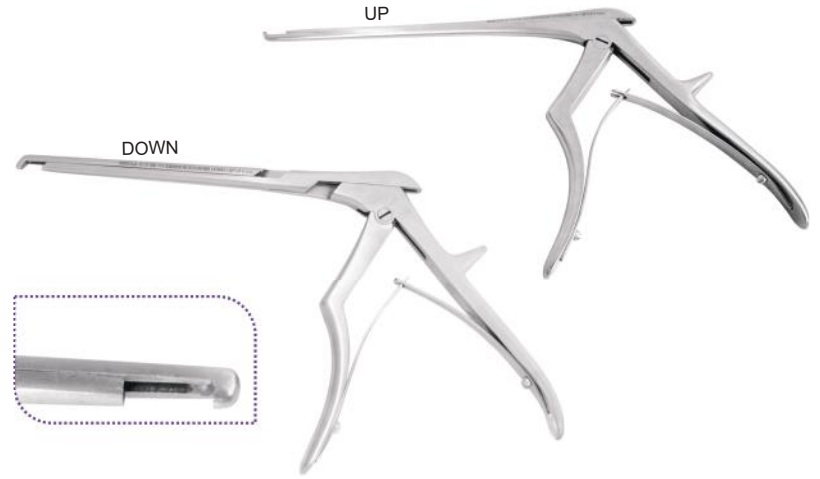

Cat. No. :716.12
Kerrison Rounger 12" Long (45° Up)

Product No. For Order

716.12.4520U = 2.0 mm
716.12.4530U = 3.0 mm
716.12.4540U = 4.0 mm



Cat. No. :717. Z
Kerrison Rounger Z Type

Product No. For Order

717.Z.4520U = 2.0 mm
717.Z.4530U = 3.0 mm
717.Z.4540U = 4.0 mm

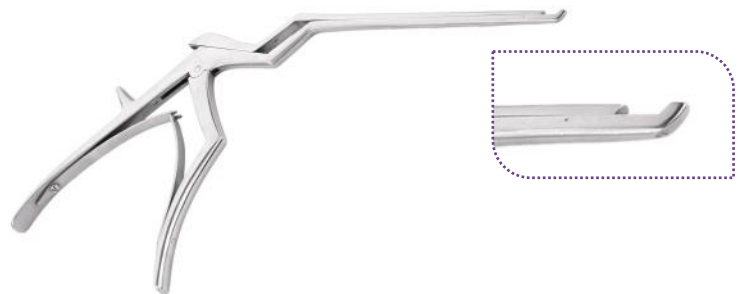

Cat. No. :718.70A
Kerrison Rounger 70° Angle (45° Up)

Product No. For Order

718.70A.4520U = 2.0 mm
718.70A.4530U = 3.0 mm
718.70A.4540U = 4.0 mm

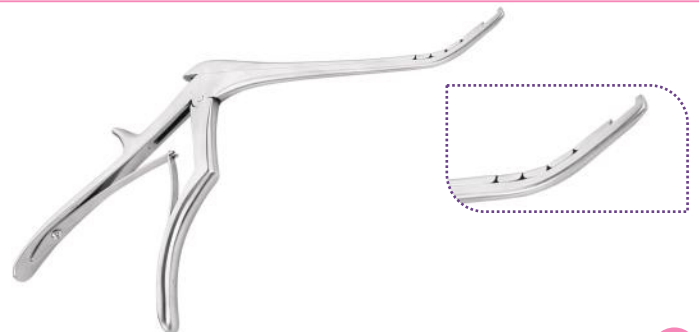

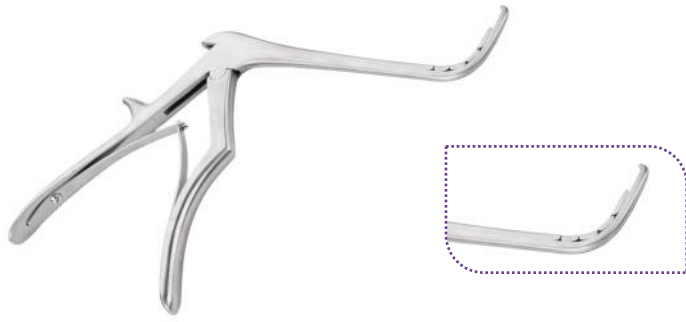

Cat. No. :718.90A
Kerrison Ronger 90° Angle (45° Up)

Product No. For Order

718.90A.4520U = 2.0 mm

718.90A.4530U = 3.0 mm

718.90A.4540U = 4.0 mm



Cat. No. :719
Bone Nibbler 90° Bend

800 • BONE HOLDING FORCEPS / CLAMPS

Cat. No. : 801
Burns Bone Holding Forceps

Product No. For Order

801.06 = Small 06"
 801.08 = Large 08"



Cat. No. 802
Burns Bone Holding Forceps Modified

Product No. For Order

802 = Small 08"



Cat. No. :803
Bone Holding For Radius / Ulna (7.5")

Product No. For Order

803.S = Straight
 803.L = Left
 803.RI = Right

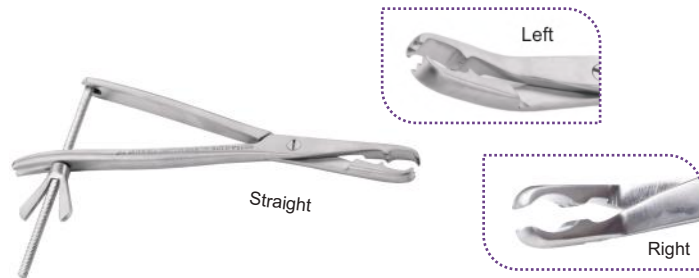

Cat. No. :803.R
Lanes Bone Holding Forceps Ratchet

Product No. For Order

803.R.08 = 08"
 803.R.10 = 10"
 803.R.12 = 12"



Cat. No. :804
Heygroves Bone Holding Forceps

Product No. For Order

804.08 = 08"
 804.10 = 10"
 804.12 = 12"



Cat. No. :805
Lowmans Clamp

Product No. For Order

805.03.DP = 03" D.P.
 805.03.SP = 03" S.P.
 805.04 = 04"
 805.06 = 06"
 805.08 = 08"
 805.10 = 10"

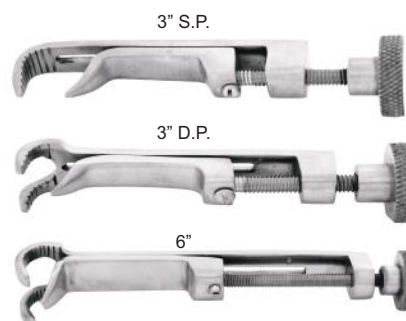



Cat. No. :806
Self - Centering Forceps

Product No. For Order

806.04 = 04"
806.06 = 06"
806.08 = 08"
806.10 = 10"
806.12 = 12"



Cat. No. :807
Reduction Forceps

Product No. For Order

807.04 = 04"
807.06 = 06"
807.08 = 08"
807.10 = 10"
807.12 = 12"



Cat. No. :807.S
Reduction Forceps Swivel Foot

Product No. For Order

807.S.35 = 3.5 mm
807.S.45 = 4.5 mm



Cat. No. :807.C
Reduction Clamp Curved



Cat. No. :808
Reduction Forceps With Pointed

Product No. For Order

808.06 = 06"
808.08 = 08"
808.10 = 10"
808.12 = 12"



Cat. No. :808.D
Reduction Forceps Pointed With Double Ratchet

Product No. For Order

808.D = 08"

800 • BONE HOLDING FORCEPS / CLAMPS

Cat. No. : 808.K
Reduction Forceps Pointed With K Wire Guide

Product No. For Order

808.K.06 = 06"
 808.K.08 = 08"

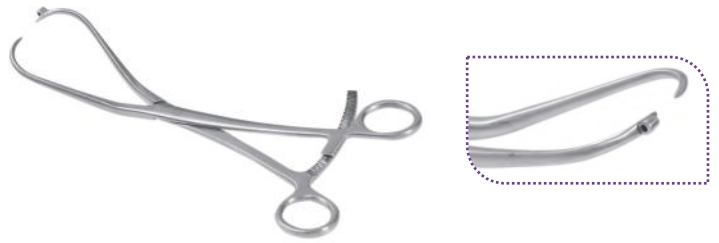

Cat. No. 808.R
Reduction Forceps Serrated Ratchet

Product No. For Order

808.R.06 = 06"
 808.R.07 = 07"



Cat. No. :809.S
Patella Bone Holding Forceps
 single prong - straight & curved

Product No. For Order

809.S.CU08 = 08"
 809.S.ST08 = 08"
 809.S.CU10 = 10"
 809.S.ST10 = 10"
 809.S.CU12 = 12"
 809.S.ST12 = 12"
 809.S.CU14 = 14"
 809.S.ST14 = 14"



Cat. No. :809.S
Patella Bone Holding Forceps
 single prong with bolt tip - straight & curved

Product No. For Order

809.S.WCU08 = 08"
 809.S.WST08 = 08"
 809.S.WCU10 = 10"
 809.S.WST10 = 10"
 809.S.WCU12 = 12"
 809.S.WST12 = 12"
 809.S.WCU14 = 14"
 809.S.WST14 = 14"



Cat. No. :809
Patella Bone Holding Forceps
 double prong with bolt tip - straight & curved

Product No. For Order

809.D.08.C = 08"
 809.D.08.S = 08"
 809.D.10.C = 10"
 809.D.10.S = 10"
 809.D.12.C = 12"
 809.D.12.S = 12"
 809.D.14.C = 14"
 809.D.14.S = 14"





Cat. No. :810
Plate & Bone Holding Forcep
With Tap & Drill Sleeve

Product No. For Order

810.08 = 08"
810.10 = 10"



Cat. No. :811
Plate & Bone Holding Forceps (Mani's Clamp)

Product No. For Order

811.07 = 07"
811.09 = 09"



Cat. No. :812
Plate & Bone Holding Forceps with Slide

Product No. For Order

812.07 = 07"
812.09 = 09"

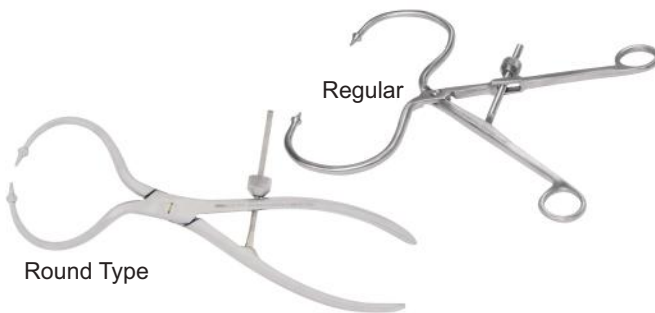

Cat. No. :814
Femur Condyle Clamp

Product No. For Order

814.R = Regular
814.RT = Round Type



Cat. No. :815
Fibula Holding Forceps

Product No. For Order

=> Straight
=> Curved



Cat. No. :816
Holding Forceps For Tibia Edge Fragment

800 • BONE HOLDING FORCEPS / CLAMPS

Cat. No. :817
Malleolar Forceps

Product No. For Order

817.08 = 8"



Cat. No. : 818
Sub Trochanteric Reduction Clamp



Cat. No. 819
Pointed Reduction Forceps

Product No. For Order

819.07 = 7"

819.08 = 8"

819.10 = 10"



Cat. No. :820
Lambotte Bone Holding Forceps

Product No. For Order

820.10 = 10"



Cat. No. :821
Phalanges Bone Holding Forceps Adjustable

Product No. For Order

821.08 = 08"





Cat. No. :S804
Heygroves Bone Holding Forceps (S.Q.)

Product No. For Order

S804.008 = Small 8"
S804.010 = Medium 10"
S804.012 = Large 12"



Cat. No. :S806
Self - Centring Forceps (S.Q.)

Product No. For Order

S806.006 = Small 6"
S806.008 = Medium 8"
S806.010 = Large 10"



Cat. No. :S807
Reduction Forceps (S.Q.)

Product No. For Order

S807.006 = Small 6"
S807.008 = Medium 8"
S807.010 = Large 10"



Cat. No. :S808
Reduction Forceps Pointed With Ratchet (S.Q.)

Product No. For Order

S808.006 = Small 6"
S808.008 = Medium 8"



Cat. No. :S323.H
Screw Driver Hex (S.Q.)
(Silicon Handle)

Product No. For Order

S323.H27 = 2.7 mm
S323.H35 = 3.5 mm
S323.H45 = 4.5 mm

S800 • BONE HOLDING FORCEPS / CLAMPS (Super Quality)

Cat. No. :613
Opened Wire Cutter



Cat. No. :S1004
Osteotomes Silicon Handle (St. & Cu.)

Product No. For Order

- S1004.06 = 06 mm
- S1004.08 = 08 mm
- S1004.10 = 10 mm
- S1004.12 = 12 mm
- S1004.15 = 15 mm
- S1004.18 = 18 mm



Cat. No. :S807.S
Reduction Forcep Small Serrated
Self Lock



Cat. No. :S807.S
Reduction Forcep Small Pointed
Self Lock





Cat. No. :901
Lane's Bone Lever Plain

Product No. For Order

901.P = Plain



Cat. No. :902
Lane's Bone Lever

Product No. For Order

902 = Serrated

902.T = Trathowen



Cat. No. :903.L
Lever for Radius / Ulna



Cat. No. :904
Mastoid Retractor

Product No. For Order

904.04 = 04"

904.06 = 06"

904.08 = 08"

904.10 = 10"



Cat. No. :904.J
Jonson Retractor 4 Prong



Cat. No.905
Dura Retractor

Product No. For Order

905.CU = CU.

905.ST = ST.

905.45 = 45°.

900 • BONE LEVERS /RETRACTORS / ELEVATORS

Cat. No. : 906 Nerve Root Retractor

Product No. For Order

- 906.45 = 45°
- 906.90 = 90°
- 906.ST = Straight

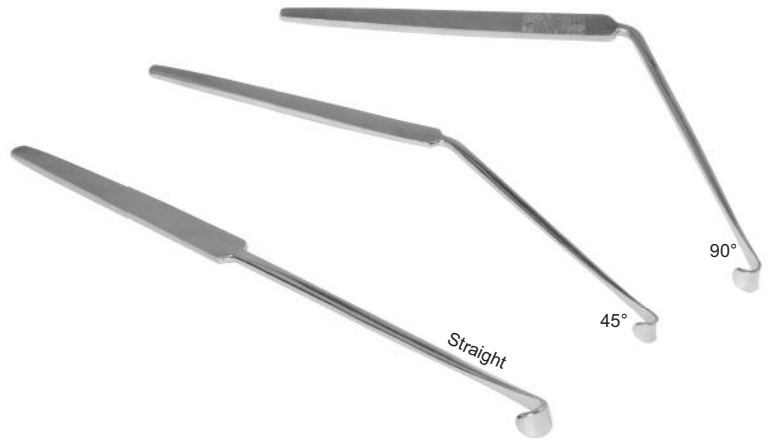

Cat. No. 906.C Nerve Root Casper Retractor

Product No. For Order

- 906.C.06 = 06 mm
- 906.C.08 = 08 mm
- 906.C.10 = 10 mm
- 906.C.12 = 12 mm



Cat. No. :907 Hohman Retractor

Product No. For Order

- 907.06.160 = 06 mm x 160 mm
- 907.08.160 = 08 mm x 160 mm
- 907.10.160 = 10 mm x 160 mm
- 907.10.220 = 10 mm x 220 mm
- 907.12.220 = 12 mm x 220 mm
- 907.15.220 = 15 mm x 220 mm
- 907.18.235 = 18 mm x 235 mm
- 907.20.235 = 20 mm x 235 mm
- 907.25.240 = 25 mm x 240 mm
- 907.30.240 = 30 mm x 240 mm
- 907.35.240 = 35 mm x 240 mm
- 907.43.240 = 43 mm x 240 mm
- 907.70.250 = 70 mm x 250 mm

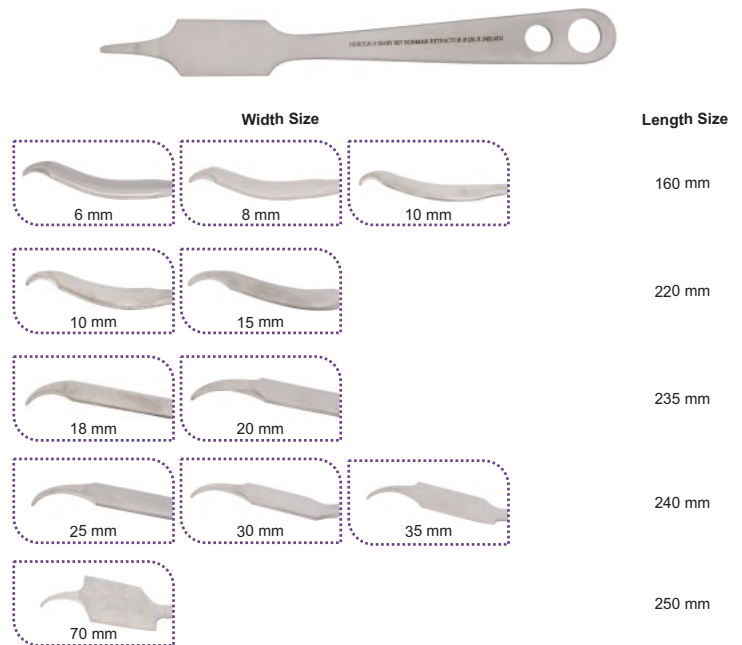

Cat. No. :907 Hohman Retractor

Product No. For Order

- 907.L = Long Tip 20 mm
- 907.W = Wide Tip 24 mm

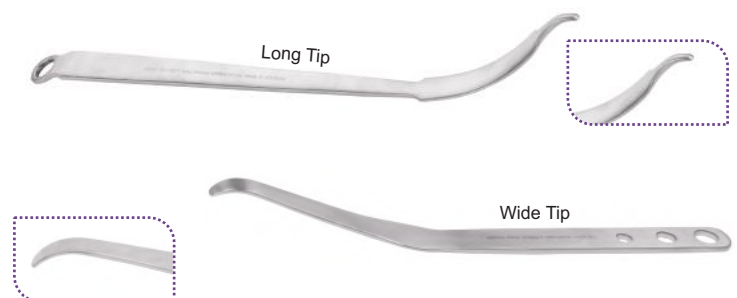



Cat. No. :907.90
Hohman Retractor 90°

Product No. For Order

907.90.18105.S = 18 mm X 105 mm St.
 907.90.18125.S = 18 mm X 125 mm St.
 907.90.20120.C = 20 mm X 120 mm Cu.
 907.90.25150.C = 25 mm X 150 mm Cu.



Cat. No. :907.45
Hohman Retractor 45°

Product No. For Order

907.45.18250 = 18 mm X 250 mm



Cat. No. :907.P
PCL Retractor

Product No. For Order

907.P.05200 = 05 mm X 200 mm



Cat. No. :907.S
Pelvic Single Prong

Product No. For Order

907.S.24280 = 24 mm X 280 mm



Cat. No. :907.LH
Lange Hohman Retractor

Product No. For Order

907.LH.25250 = 25 mm X 250 mm
 907.LH.M = Modified (290 X 33) mm



Cat. No.907.A
Aldinger Hohman Retractor

Product No. For Order

907.A = 280mm X 23 mm

900 • BONE LEVERS /RETRACTORS / ELEVATORS

Cat. No. : 908
Cut's Paw Retractor



Cat. No. 909
Hook (volkman) Retractor

Product No. For Order

909.03 = 03 Prong

909.04 = 04 Prong



Cat. No. :910
Leminectomy Retractor followup blade

Product No. For Order

910.08 = 8" (Small)

910.10 = 10" (Medium)

910.12 = 12" (Large)



Cat. No. :911
Hip Retractor

Product No. For Order

911.C = Hip Retractor Curved (25mm)

911.D = Hip Retractor Double Bend
(45 X 50 mm)



Cat. No. :912
Skin Hook

Product No. For Order

912.S = Single

912.D = Double

912.T = Triple



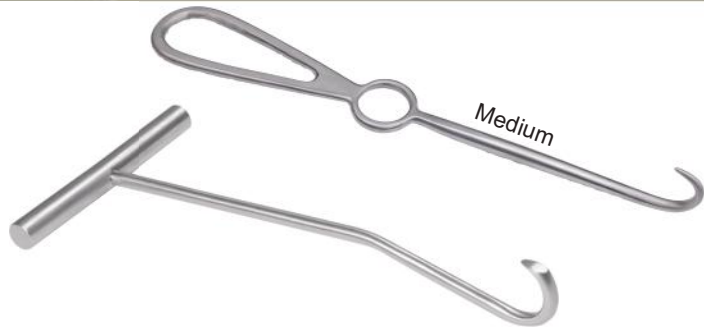

**Cat. No. :913
Bone Hook**

Product No. For Order

- 913.S = Small
- 913.M = Medium
- 913.L = Large
- 913.EL = Extra Large



**Cat. No. :914
Bristow Periosteal Elevator**

Product No. For Order

- 914.S = Straight
- 914.C = Curved



**Cat. No. :915
Graft Impactor Alluminium Handle Rectangle**

Product No. For Order

- 915.0316 = 03 mm X 16 mm
- 915.0611 = 06 mm X 11 mm
- 915.0710 = 07 mm X 10 mm
- 915.0713 = 07 mm X 13 mm
- 915.1010 = 10 mm X 10 mm



**Cat. No. :915.S
Graft Impactor Alluminium Handle Shoe Shape**

Product No. For Order

- 915.S = 6 mm X 13 mm



**Cat. No. :915.L
Graft Impactor Alluminium Handle L Shape**

Product No. For Order

- 915.L = 5 mm X 11 mm



**Cat. No. :915.R
Graft Impactor Alluminium Handle Round**

Product No. For Order

- 915.R.07 = 07 mm
- 915.R.10 = 10 mm

900 • BONE LEVERS /RETRACTORS / ELEVATORS

Cat. No. : 915.RB
Graft Impactor Alluminium Handle
Round Bionet

Product No. For Order

915.RB.07 = 07 mm

915.RB.10 = 10 mm



Cat. No. 915.B
Graft Impactor Alluminium Handle Rectangle Bionet

Product No. For Order

915.B.0710 = 7 mm X 10 mm

915.B.1010 = 10 mm X 10 mm



Cat. No. :917
Mitchell Elevator

Product No. For Order

917.S = Straight

917.C = Curved



Cat. No. :918
Periosteal Elevator St. / Cu.

Product No. For Order

918.05.S = 05 mm ST.

918.05.C = 05 mm CU.

918.10.S = 10 mm ST.

918.10.C = 10 mm CU.

918.15.S = 15 mm ST.

918.15.C = 15 mm CU.



Cat. No. :918.B
Periosteal Elevator Curved Blade 06 mm

Product No. For Order

918.B.S = Square edge

918.B.R = Round edge



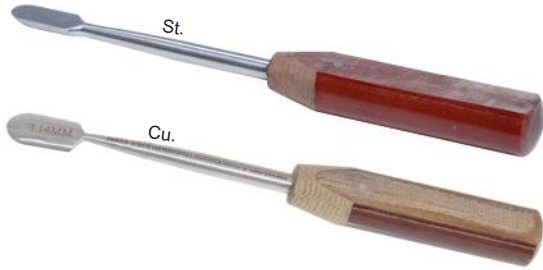

Cat. No. :918.FR
Periosteal elevator F. H. Round Edge St. / Cu.

Product No. For Order

- 918.FR.12.S = 12 mm ST.
- 918.FR.12.C = 12 mm CU.
- 918.FR.14.S = 14 mm ST.
- 918.FR.14.C = 14 mm CU.



Cat. No. :918.FS
Periosteal elevator F. H. Square Edge St. / Cu.

Product No. For Order

- 918.FS.06.S = 06 mm ST.
- 918.FS.06.C = 06 mm CU.
- 918.FS.08.S = 08 mm ST.
- 918.FS.08.C = 08 mm CU.
- 918.FS.10.S = 10 mm ST.
- 918.FS.10.C = 10 mm CU.
- 918.FS.12.S = 12 mm ST.
- 918.FS.12.C = 12 mm CU.
- 918.FS.14.S = 14 mm ST.
- 918.FS.14.C = 14 mm CU.

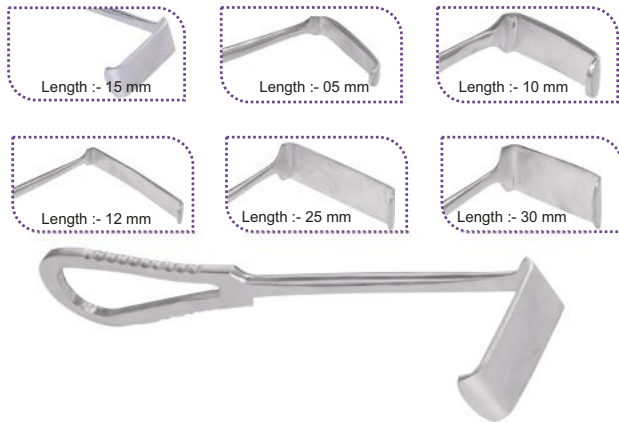

Cat. No. :919
C Retractor (right angle retractor)

Product No. For Order

- 919.05 = 05 mm
- 919.10 = 10 mm
- 919.1280 = 12 mm X 80 mm
- 919.15 = 15 mm
- 919.2060 = 20 mm X 60 mm
- 919.2565 = 25 mm X 65 mm
- 919.2580 = 25 mm X 80 mm
- 919.3070 = 30 mm X 70 mm



Cat. No. :920
Cobbs Elevator

Product No. For Order

- 920.10 = 10 mm
- 920.15 = 15 mm
- 920.20 = 20 mm

900 • BONE LEVERS /RETRACTORS / ELEVATORS

**Cat. No. :921
Gelpi Retractor Long**

Product No. For Order

921.LS.6008 = Spike 60 mm X 8"
921.LB.106008 = Blade 10 mm X 60 mm X 8"



**Cat. No. :921
Gelpi Retractor**

Product No. For Order

921.06 = Small 06"
921.08 = Large 08"



**Cat. No. :921
Codman Tissue Retractor (Gelpi Retractor)**

Product No. For Order

921.C.06 = Small 06"
921.C.08 = Large 08"



**Cat. No. : 922
Tunnelor With Fiber Handle (Mipo Elevator)**

Product No. For Order

12 mm x 225 mm
16 mm x 225 mm x 325 mm



**Cat. No. 925
Cervicle Casper Spreader**



**Cat. No. :926
Cervical Retractor With 10 Blades**

Product No. For Order

926.08 = Medium 08"
926.10 = Large 10"





**Cat. No. :927
Lamina Spreader**

Product No. For Order
927.08 = 08"
927.10 = 10"
927.12 = 12"



**Cat. No. :928
Ramanis' Retractor With 6 Blades**

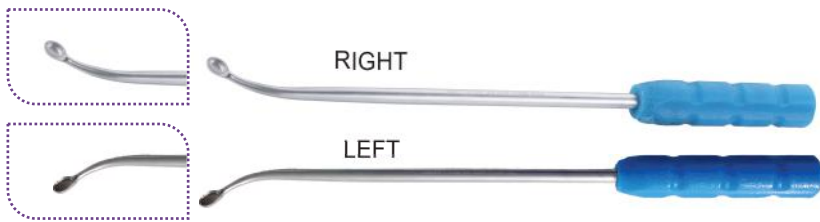

**Cat. No. :929
Bone Curret Fiber Handle
(With Silicon Handle)**

Product No. For Order
Right
Left
Straight



**Cat. No. :930.S
Ring Curret**

Product No. For Order
930.S = Straight 3 mm = 1/8
930.S = Straight 5 mm = 3/16
930.S = Straight 6 mm = 1/4



**Cat. No. :930.C
Rign Curret**

Product No. For Order
930.C = Curved 3 mm = 1/8
930.C = Curved 5 mm = 3/16
930.C = Curved 6 mm = 1/4



**Cat. No. :930.DB
Ring Curret**

Product No. For Order
930.D = Double Bend 3 mm = 1/8
930.D = Double Bend 5 mm = 3/16
930.D = Double Bend 6 mm = 1/4

900 • BONE LEVERS /RETRACTORS / ELEVATORS

Cat. No. :931
MC Donald Dissector



Cat. No. :932
Sachet Retractor

Product No. For Order

921.C.06 = Small 06"

921.C.08 = Large 08"



Cat. No. : 933
Micro Prob With Ball Tip

Product No. For Order

933.S = Straight

933.C = Curved

933.D = Double Bend



Cat. No. 934
Elevator With Prob



Cat. No. :935
Prob Dissactor (swedish)



Cat. No. :936
Killan Dissector

Product No. For Order

Straight





Cat. No. :937
Howarth Elevator



Cat. No. :938
ALM Retractor

1000 • OSTEOTOME / GOUG/ CHISEL

Cat. No. :1001 Osteotomes S.S. handle

Product No. For Order

1001.S.05 = 05 mm St.
 1001.C.05 = 05 mm Cu.
 1001.S.10 = 10 mm St.
 1001.C.10 = 10 mm Cu.
 1001.S.15 = 15 mm St.
 1001.C.15 = 15 mm Cu.
 1001.S.20 = 20 mm St.
 1001.C.20 = 20 mm Cu.
 1001.S.25 = 25 mm St.
 1001.C.25 = 25 mm Cu.



Cat. No. :1004 Osteotomes Fiber Handle

Product No. For Order

1004.S.05 = 05 mm St.
 1004.C.05 = 05 mm Cu.
 1004.S.10 = 10 mm St.
 1004.C.10 = 10 mm Cu.
 1004.S.15 = 15 mm St.
 1004.C.15 = 15 mm Cu.
 1004.S.20 = 20 mm St.
 1004.C.20 = 20 mm Cu.
 1004.S.25 = 25 mm St.
 1004.C.25 = 25 mm Cu.



Cat. No. :1005 Gauge Fiber Handle

Product No. For Order

1005.S.05 = 05 mm St.
 1005.C.05 = 05 mm Cu.
 1005.S.10 = 10 mm St.
 1005.C.10 = 10 mm Cu.
 1005.S.15 = 15 mm St.
 1005.C.15 = 15 mm Cu.
 1005.S.20 = 20 mm St.
 1005.C.20 = 20 mm Cu.
 1005.S.25 = 25 mm St.
 1005.C.25 = 25 mm Cu.



Cat. No. :1006 Chisel Fiber Handle

Product No. For Order

1006.S.05 = 05 mm St.
 1006.S.10 = 10 mm St.
 1006.S.15 = 15 mm St.
 1006.S.20 = 20 mm St.
 1006.S.25 = 25 mm St.





Cat. No. :1007
Fine Osteotomes Small S.S. Handle

Product No. For Order

1007.02 = 02 mm
1007.03 = 03 mm
1007.04 = 04 mm
1007.06 = 06 mm
1007.08 = 08 mm



Cat. No. :1008
Capner Gauge

Product No. For Order

1008.S.10 = 10 mm St.
1008.C.10 = 10 mm Cu.
1008.Dc.10 = 10 mm Dc



Cat. No. : 1009
Corticotome Osteotomes Fiber Handle

Product No. For Order

1009.10 = 10 mm
1009.15 = 15 mm



Cat. No.1011
Stilly Osteotome

Product No. For Order

1011.05 = 05 mm
1011.10 = 10 mm
1011.15 = 15 mm



Cat. No. : 850
Osteotomy Chisel

Product No. For Order

850.10 = 10 mm
850.15 = 15 mm
850.20 = 20 mm
850.25 = 25 mm

1200 • A. M. PROSTHESIS INSTRUMENT

Cat. No. : 1201
Pr Head Extractor (Judet)



Cat. No.1202
Pr Head Impactor Nylon Faced



Cat. No. :1203
Pr Rasp With Tomy Bar A.M.P.



Cat. No. :1203.D
Pr Rasp With Tomy Bar (Dotted)

Product No. For Order

1203.D.01 = 01



Cat. No. :1203.N
Pr Rasp With Tomy Bar (Narrow Stem)

Product No. For Order

1203.N.D = Dotted

1203.N.R = Regular



Cat. No. : 1204
Pr Head Gauge Set

Product No. For Order

1204.01 = 37 To 53 mm

1204.02 = 38 To 54 mm





Cat. No. :1205
Pr Murphy Skid



Cat. No. :1206
Extractor Set Of Prosthesis/K Nail/ Endre's



Cat. No. :1207
Pr Extra Hook

1300 • INSTRUMENTS FOR 4.0 MM

Cat. No. : 1301
Angle Guide Handle 1.0 mm



Cat. No. 1302
Drill Bits 3.2 mm Cannulated



Cat. No. :1303
Bone Tap 4.0 mm Cannulated



Cat. No. :1304
Screw Driver 3.5 mm Cannulated



Cat. No. :197.09
Guide Wire Simple 09"

Product No. For Order

197.09 = 01 mm



Cat. No. : 1611
Measuring Device

Product No. For Order

1611 = 1.2 mm





Cat. No. :1401
Angle Guide Handle 1.8 mm

Product No. For Order

1401 = 1.8 mm



Cat. No. 1402
Drill Bits 4.5 mm Cannulated



Cat. No. :1403
Bone Tap 6.5 mm Cannulated

Product No. For Order

1403 = 6.5 mm

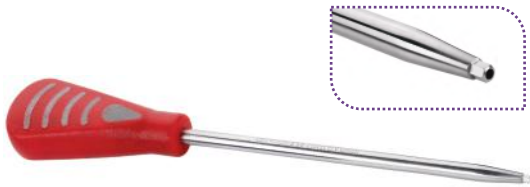

Cat. No. :1404
Screw Driver 4.5 mm Cannulated

Product No. For Order

1404 = 4.5 mm



Cat. No. :197
Guide Wire Simple 09''

Product No. For Order

197.09.18 = 1.8 mm



Cat. No. :1611
Measuring Device 1.8 mm

1400 • INSTRUMENT FOR 6.5 C.C. SCREW

Cat. No. :1405
Parallel Guide Adjustable For
6.5 mm C.C. Screw



Cat. No. :1406
Multi Angle Guide For C.C. Screw





Cat. No. :1501
Triple Action Reamer

Product No. For Order

1501.95° = 95° Barrel
1501.L = Long Barrel
1501.S = Short Barrel



Cat. No. 1502
Angle Guide Adjustable



Cat. No. :1503
Tap For D.H.S. Screw



Cat. No. :1505
D.H.S Guide Wire Pusher

1600 • INSTRUMENT FOR D.H.S. / D.C.S. (Q.C.)

Cat. No. :1601
Triple Action Reamer (Q.C.)

Product No. For Order

1601.95° = 95° Barrel
1601.L = Long Barrel
1601.S = Short Barrel



Cat. No. :1601.M
Triple Action Reamer (Q.C.)

=> Man Man Type



Cat. No. :1601.S
Triple Action Reamer (Q.C.) (S.Q.)

Product No. For Order

1601.S.L = Long Barrel
1601.S.S = Short Barrel



Cat. No. :1602
Angle Guide Fix (Q.C.)

Product No. For Order

1602.095° = 095°
1602.125° = 125°
1602.130° = 130°
1602.135° = 135°
1602.140° = 140°
1602.145° = 145°



Cat. No. :1603
Tap For D.H.S. Screw (Q.C.)



Cat. No. :1603.M
Tap For D.H.S. Screw (Q.C.)

=> Man Man Type





Cat. No. :1604
Screw Introducer (Wrench)



Cat. No. :1605
Compression Instrument



Cat. No. :1606
D.H.S Plate Holder



Cat. No. :1607
Impactor with Nylon Faced



Cat. No. :1608
T-Handle For Quick Coupling



Cat. No. :1609
Centering Sleeve For Tap

1600 • INSTRUMENT FOR D.H.S. / D.C.S. (Q.C.)

Cat. No. :1610
Centering Sleeve For Wrench



Cat. No. :1611
Measuring Device 2.5 mm



Cat. No. :1612
D.H.S. Plate Guide



Cat. No. :197
Guide Wire Simple 09"

Product No. For Order

197.09.25 = 2.5 mm



Cat. No. :1613
Angle Guide Handle 2.5 mm





Cat. No. :1601.PQ
Triple Action Reamer (Q.C.)



Cat. No. :1603.P.Q.
Tap For D.H.S. Screw (Q.C.)



Cat. No. :1604.P
Screw Introducer (Wrench)

1700 • INSTRUMENTS FOR HARBERT SCREW

Cat. No. :1701
Drill Bits 2.5 mm Cannulated



Cat. No. :1702
Drill Bits 3.2 mm Cannulated



Cat. No. :1703
Bone Tap Cannulated

Product No. For Order

1703.35 = 3.5 mm
1703.45 = 4.5 mm



Cat. No. :1304
Screw Driver 3.5 mm Cannulated



Cat. No. :197
Guide Wire Simple 09"

Product No. For Order

197.09.10 = 1.0 mm



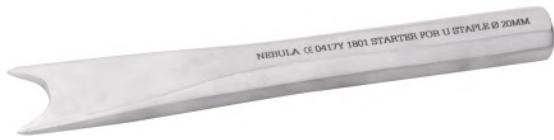

Cat. No. :1801
Starter For U Staple

Product No. For Order

1801.10 = 10 mm
1801.15 = 15 mm
1801.20 = 20 mm
1801.25 = 25 mm



Cat. No. :1802
Inserter For U Staple



Cat. No. :1803
Extractor For Staple

Product No. For Order

1803.C = Coventary Staple
1803.U = U Staple



Cat. No. :1804
Inserter For Coventary Staple

1900 • INSTRUMENT FOR RADIUS / ULNA NAILING

Cat. No. :1901
Square / Rush Nail Reamer

Product No. For Order

1901.20 = 2.0mm
1901.25 = 2.5 mm
1901.30 = 3.0mm
1901.35 = 3.5 mm
1901.40 = 4.0 mm

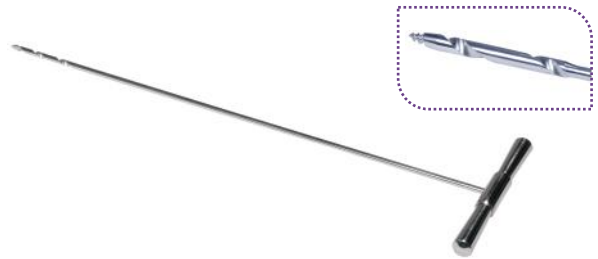

Cat. No. :1902
Pointed Impactor (Punch)

Product No. For Order

1902.S = Straight
1902.C = Curved



Cat. No. :1903
Square Nail Extractor Hook

Product No. For Order

1903.20 = 2.0mm
1903.25 = 2.5 mm
1903.30 = 3.0mm
1903.35/40 = 3.5/4.0 mm



Cat. No. :1904
Square nail Extractor Plier Type



Cat. No. :1905
Bone Awl With Alluminium Handle

Product No. For Order

1905.S = Straight
1905.C = Curved





Cat. No. :1906
Rush Nail With Impactor / Bender



Cat. No. :1907
Cobbblers Awl Set of 3



Cat. No. :1908
Bone Awl curved Radius / Ulna

2000 • INSTRUMENT SET FOR K NAIL

Cat. No. :2001
K Nail Guide Wire

Product No. For Order

2.5 mm
3.0 mm



Cat. No. :2002
K nail Reamer

Product No. For Order

2002.06 = 06 mm
2002.07 = 07 mm
2002.08 = 08 mm
2002.09 = 09 mm
2002.10 = 10 mm
2002.11 = 11 mm
2002.12 = 12 mm



Cat. No. :311
Drill & Screw Gauge

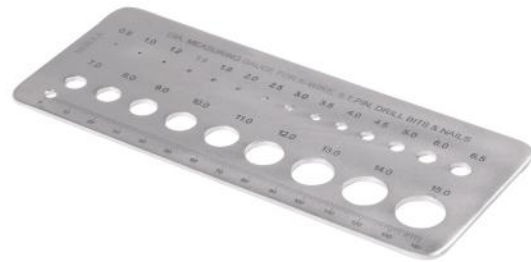

Cat. No. :2004
K Nail Impactor With Pointed



Cat. No. 2005
K Nail Impactor Slotted





Cat. No. :1206
Extractor Set Of K Nail



Cat. No. :2007
K Nail Hook Extra

2200 • INSTRUMENT SET FOR ENDER'S NAIL

Cat. No. :2201
Extra Hook



Cat. No. :2202
Bender 2 Nos.



Cat. No. :1206
Extractor Set Of Ender's



Cat. No. :2204
Ender's Impactor

Product No. For Order

3.5 mm

4.5 mm



Cat. No. :2204.E
Impactor Extra



Cat. No. :2205
Awl (T - Handle Type)





Cat. No. :3001
Mini Screw & Plate Holding Forceps



Cat. No. :3002
Mini Screw Driver (Cross Head) 3 in 1

Product No. For Order

3002.01 = 01



Cat. No. :3003
Mini Screw Driver (Slot)

Product No. For Order

3003.15 = 1.5 mm
3003.20/25 = 2.0 mm / 2.5 mm



Cat. No. :3004
Mini Williams Screw Driver (Slot)

Product No. For Order

3004.15 = 1.5 mm
3004.20 = 2.0 mm
3004.25 = 2.5 mm



Cat. No. :3005
Mini Depth Gauge



Cat. No. :3006
Mini Sleeve With Pointer

3000 • INSTRUMENT SET FOR MINI PLATES

Cat. No. :3007
Mini Plate Bender Plier Type (With 3 Pin)



Cat. No. :3008
Mini Wire Cutter



Cat. No. :3009
Mini Self Centering Forceps



Cat. No. :3010
Mini Lever For Dental

Product No. For Order

3010.06 = 06 mm
3010.08 = 08 mm



Cat. No. :3011
Mini Dental Drill With Collet



Cat. No. :3012
Mini Screw Box With S.S. Tray

Product No. For Order

3012.15 = 1.5 mm
3012.20 = 2.0 mm
3012.25 = 2.5 mm





Cat. No. :3013
Mini Mesh Bender



Cat. No. :3017
Mini Plier For Dental

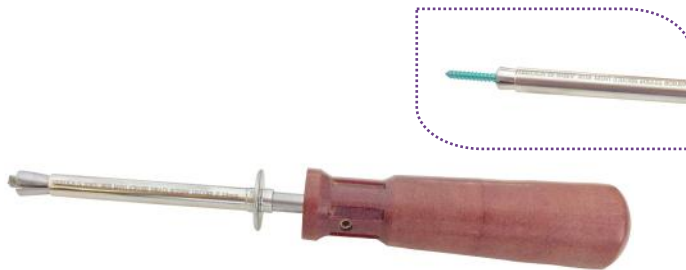

Cat. No. :3018
Mini Screw Driver (Cross Head)

Product No. For Order

3018.15 = 1.5 mm
3018.20 = 2.0 mm
3018.25 = 2.5 mm

3100 • INSTRUMENT SET FOR ELASTIC NAIL

Cat. No. :3101
T - Handle With Chuck



Cat. No. :3102
Impactor For Ten Nail

Size : 2.0 ,2.5, 3.0, 3.5, 4.0, 4.5 mm

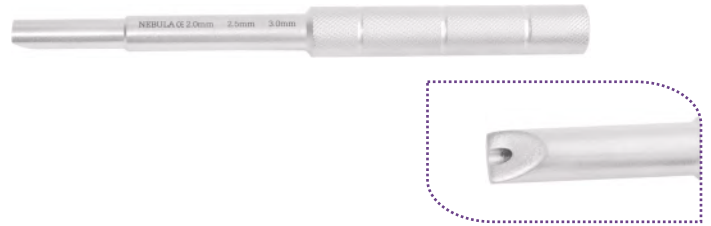

Cat. No. :3103
Extractor Rod



Cat. No. :3104
Round Hammer

Product No. For Order

3010.06 = 06 mm
3010.08 = 08 mm



Cat. No. :2205
Awl (T - Handle Type)



Cat. No. :330
Rod Pin Cutter 14"

Product No. For Order

330.S = Silver





Cat. No. :3105
Extractor Plier (Vice Grip)



Cat. No. :3106
T - Handle For Elastic Nail Cap

Product No. For Order

3106.08 = 08 mm
3106.10 = 10 mm



Cat. No. :3107
Bone Awl Straight For Ten Nail

3200 • INSTRUMENT SET FOR BIPOLAR

Cat. No. :3201
Rasp With Tomy Bar



Cat. No. :3201.BHU
Rasp With Tomy Bar (BHU)

Size : Fenestrated
Non Fenestrated



Cat. No. :3203
Straight Reamer



Cat. No. 3204
Pointed Impactor Punch



Cat. No. :3205
Box Punch (Hollow Chisel)



Cat. No. :3206
Trial Cup 37mm To 55 mm

Product No. For Order





**Cat. No. :3207
Trail Stem**



**Cat. No. 1201
Head Extractor (Judet)**



**Cat. No. :1202
Head Impactor Nylon Faced**



**Cat. No. :1204
Head Guade Set**



**Cat. No. : 3209
Retaining Impactor For Biopolar**

Product No. For Order

37 mm x 53 mm
38 mm x 54 mm

• GENERAL INSTRUMENT

Cat. No. :G.101
Sponge Holding Forcep

Product No. For Order

G.101.08 = 8"

G101.10 = 10"



Cat. No. :G.102
Towel Clip



Cat. No. :G.103
B.P. Handle

Product No. For Order

G.103.03 = 03 No.

G103.04 = 04 No.



Cat. No. :G.104
Chittal Forcep

Product No. For Order

G.104.08 = 08"

G104.10 = 10"

G104.12 = 12"



Cat. No. :G.105
Artery Forcep

Product No. For Order

G.105.05.C = 05" CU.
G.105.05.S = 05" ST.
G.105.06.C = 06" CU.
G.105.06.S = 06" ST.
G.105.07.C = 07" CU.
G.105.07.S = 07" ST.
G.105.08.C = 08" CU.
G.105.08.S = 08" ST.
G.105.10.C = 10" CU.
G.105.10.S = 10" ST.





**Cat. No. :G.106
Ellis Tissue Forcep**

Product No. For Order

G.106.04 = 4"
G.106.05 = 5"
G.106.06 = 6"
G.106.07 = 7"
G.106.08 = 8"



**Cat. No. :G.107
Towel Forcep**

Product No. For Order

G.107.04 = 04"
G.107.05 = 05"
G.108.06 = 06"



**Cat. No. : G.108
Niddle Holder**

Product No. For Order

G.108.05 = 05"
G.108.06 = 06"
G.108.07 = 07"
G.108.08 = 08"



**Cat. No.G.109
Mosquito Artery Forcep**

Product No. For Order

G.109.04.C = 04" CU.
G.109.04.S = 04" ST.
G.109.05.C = 05" CU.
G.109.05.S = 05" ST.
G.109.06.C = 06" CU.
G.109.06.S = 06" ST.



**Cat. No. : G.110
Dressing Scissor**

Product No. For Order

G.110.05.C = 05" CU.
G.110.05.S = 05" ST.
G.110.06.C = 06" CU.
G.110.06.S = 06" ST.
G.110.07.C = 07" CU.
G.110.07.S = 07" ST.
G.110.08.C = 08" CU.
G.110.08.S = 08" ST.

• GENERAL INSTRUMENT

**Cat. No. :G.111
Mayo Scissor**

Product No. For Order

G.111.65.C = 6.5" CU.
G.111.65.S = 6.5" ST.
G.111.75.C = 7.5" CU.
G.111.75.S = 7.5" ST.
G.111.85.C = 8.5" CU.
G.111.85.S = 8.5" ST.



**Cat. No. :G.112
Stich Removal Scissor**



**Cat. No. :G.113
Cuticle Scissor**

Product No. For Order

G.113.04.C = 04" CU.
G.113.04.S = 04" ST.
G.113.05.C = 05" CU.
G.113.05.S = 05" ST.



**Cat. No. :G.114
Bone Scoop Double Ended**

Product No. For Order

G.114.06 = 06"
G114.07 = 07"
G114.08 = 08"



**Cat. No. :G.114.F
Bone Scoop (Curret) Fiber Handle**

Product No. For Order

G.114.F.03 = 03 mm
G.114.F.04 = 04 mm
G.114.F.05 = 05 mm
G.114.F.06 = 06 mm
G.114.F.07 = 07 mm
G.114.F.08 = 08 mm





**Cat. No. :G.115
Dissecting Forcep Plain**

Product No. For Order

G.115.05 = 5"
G.115.06 = 6"
G.115.07 = 7"
G.115.08 = 8"
G.115.10 = 10"



**Cat. No. :G.116
Babcock Tissue Forcep**

Product No. For Order

G.116.06 = 06"
G.116.08 = 08"



**Cat. No. : G.117
Dissecting Forcep Teeth**

Product No. For Order

G.117.05 = 05"
G.117.06 = 06"
G.117.07 = 07"
G.117.08 = 08"
G.117.10 = 10"



**Cat. No.G.118
Kokkes Forcep**

Product No. For Order

G.118.06 = 06"
G.118.08 = 08"



**Cat. No. : G.119
Debakey Teeth Forcep**

Product No. For Order

G.119.CU06 = 06" CU.
G.119.ST06 = 06" ST.
G.119.CU07 = 07" CU.
G.119.ST07 = 07" ST.
G.119.CU08 = 08" CU.
G.119.ST08 = 08" ST.

• GENERAL INSTRUMENT

Cat. No. :G.120
Safety Pin

Product No. For Order

G.120.06 = 06"

G.120.08 = 08"



Cat. No. :G.121
Tonsil (Metzabaum) Scissor

Product No. For Order

G.121.06.C = 06" CU.

G.121.06.S = 06" ST.

G.121.07.C = 07" CU.

G.121.07.S = 07" ST.

G.121.08.C = 08" CU.

G.121.08.S = 08" St.



Cat. No. :G.122
Tonsil (Metzabaum) Scissor (T/C Tip)

Product No. For Order

G.122.06 = 06"

G.122.07 = 07"

G.122.08 = 08"



Cat. No. :G.123
Niddle Holder (T/C Tip)

Product No. For Order

G.123.06 = 06"

G123.07 = 07"

G123.08 = 08"



Cat. No. :G.124
Lister Scissor (Bendage)

Product No. For Order

G.124.06 = 06"

G.124.08 = 08"





**Cat. No. :G.125
Right Angle Artery Forcep**

Product No. For Order

G.125.06 = 6"



**Cat. No. :G.126
Biyonet Forcep**

Product No. For Order

G.126.P = Plain
G.126.T = Teeth



**Cat. No. : G.127
Adson Forcep Teeth**

Product No. For Order

G.127.05 = 05"
G.127.06 = 06"



**Cat. No.G.128
Adson Forcep Plain**

Product No. For Order

G.128.05 = 05"
G.128.06 = 06"



**Cat. No. : G.129
Bozman Niddle Holder**

Product No. For Order

G.129.06 = 06"
G.129.08 = 08"



**Cat. No.G.130
Niddle Holder With Scissor**

Product No. For Order

G.130.07 = 07"

• GENERAL INSTRUMENT

Cat. No. : G.131
Mayo Scissor



Cat. No. : G.131
Iris Scissor





Nebula Surgical Pvt. Ltd.

Office: "Nebula" Narmada Park-3,
Opp. King's Height, Vidhya Kunj Society Main Road,
Amin Marg, Rajkot-360005. Ph.:+91 281 2584832/33,

Factory : G-1921/3, Almighty Gate Main Road,
G.I.D.C. Metoda-360021. Gujarat (INDIA)
Phone: +91 2827 297570.

Web : www.nebulasurgical.com
Email : info@nebulasurgical.com
export@nebulasurgical.com